



GEO Semiconductor Inc.

GC6500

1080p60 H.264 Camera Codec with High Dynamic Range ISP

General Description

The GC6500 is a highly integrated, low-power H.264 Codec that supports video encoding up to High Definition (1920 x 1080p60) resolution. The GC6500 features advanced video encoding and processing with HD H.264 encoder and processors such as High Dynamic Range (HDR) Image Signal Processor (ISP), Geometric processor (eWarp), and Video preprocessors. The device also incorporates an Xtensa LX4 processor and a RISC processor along with a number of peripheral and serial device interfaces for I/O and system control integration.

Combining high-quality video encoding with advanced video processing, the GC6500 is an ideal, cost-effective solution for secured video monitoring and internet video conferencing applications.

Leveraging the chip's high performance and integration capabilities, the GC6500 delivers superior video and audio quality while significantly reducing cost and power consumption of the system. The advanced video processing blocks coupled with the flexible hardware architecture provide best in class video processing capabilities such as ultra wide angle and fish-eye correction, wide dynamic range video processing, and multi-stream encoding support. The audio processing algorithms such as beam forming, noise suppression, and echo cancellation implemented in the firmware improve signal noise ratio removing the need for external audio processing. The integrated Analog to Digital Converter (ADC) and power circuitry eliminate the need for external components reducing overall system cost.

System Block Diagram

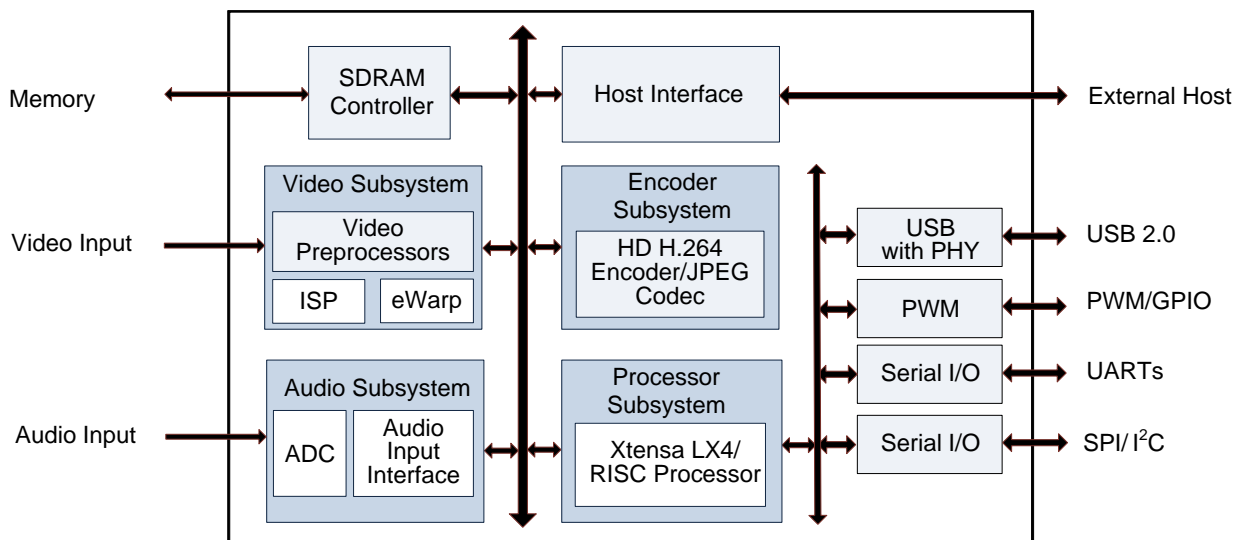



GEO Semiconductor Inc.

The highly programmable geometric correction engine, eWarp, can correct for complex lens distortion, perspective and rotational misalignment. The programmable blocks allow custom non-linear transforms to be implemented including applying independent transforms to different parts of the image.

The embedded HDR ISP provides excellent high-quality video even in challenging lighting conditions such as bright sunshine through windows in a home or office.

The integrated Xtensa processor implements custom instructions, flexible data paths, and simultaneous data operations to enhance the processor performance. The firmware running on the processors manages data flow and implements several audio and video processing algorithms. Advance features such as face detection, gesture recognition, and video analytics can be implemented in firmware using generated heuristics.

Building upon GEO's deep foundation in video compression, the H.264 hardware encoder can simultaneously compress multiple video streams. The resulting streams can be transferred through the USB high-speed link to a host device or directly to the cloud over WiFi or 3G/4G wireless signals.

Features

Video Processing

- Single, two-lane Mobile Industry Processor Interface (MIPI)
- 8-, 10-, and 12-bit Bayer RGB or 8-bit YUV 4:2:2 video input
- Integrated ISP module capable of processing Bayer RGB up to 5MP at 30fps
- HDR processing block in the ISP
- 2D Overlay Engine for graphics overlay
- Spatial and Temporal (3D) noise filtering
- Horizontal and Vertical Scalars using 8-tap polyphase filters
- Auto White Balance, Auto Exposure, Auto Focus

eWarp

- Programmable warp maps for almost any distortion correction
- Real-time generation of warp maps
- Fisheye corrections for 180 and 360 degree views
- Full warp capability for targeted resolutions of 5MP at 30fps

Video Codecs

- High Definition (HD) or Standard Definition (SD) H.264 encoder
- High, Main, and Baseline profiles support for resolutions up to 1920 x 1080 at 60fps
- Multi-stream encoding
- H.264 encoder up to level 4.1
- Programmable resolutions and frame rates
- Video bit rates: 25Kbps to 62.5Mbps
- HD JPEG encoder and decoder up to 1920 x 1080 at 30fps

Audio Processing

- Integrated ADC
- Two I²S audio input ports or two stereo digital microphone inputs
- Sampling rates from 8kHz to 48kHz
- Two- or four-microphone array beam forming support
- Audio noise reduction
- Voice recognition in ultra-low power mode
- Advanced Audio Coding-Low Complexity (AAC-LC) encoder support



GEO Semiconductor Inc.

Processor Subsystem

- Xtensa LX4 32-bit processor operating up to 400MHz
- 64KB Instruction cache, 32KB Data cache, 16KB Local data RAM

Memory Interface

- DDR3 SDRAM memory up to 533MHz
- DDR2 or LPDDR2 SDRAM support up to 400MHz
- 16-bit memory interface supporting up to 2Gb memory device

Peripheral Interfaces

- USB 2.0 Hi-speed including PHY interface
- Two SPI, I²C, and UART ports
- Three PWMs
- Up to 24 GPIO pins

Power and Voltage

- Core voltage: 1.1V \pm 5%
- DDR SDRAM voltages: DDR3: 1.5V, DDR2: 1.8V and LPDDR2: 1.2V
- I/O voltages: 1.8V \pm 5%, 3.3V \pm 5%
- On-chip audio/video Phase Lock Loops (PLLs) driven from a single crystal
- Typical power consumption is 470mW or less

Packaging

- 223-pin TFBGA, 8mm x 10mm x 1.1mm, 0.5mm pitch, RoHS compliant

Applications

- H.264 USB Compression Camera
- Wireless Home Monitoring Camera
- Wearable Camera
- Smart TV Camera
- Cloud Camera

Ordering Information

Part Number	Package: Type, Pins, Code	RoHS/ Lead-Free
GC6500	223-pin TFBGA, 8 mm x 10 mm x 1.1 mm, 0.5 mm pitch	RoHS/ Lead-Free